

# ROOT CROP PEELERS/WASHERS/SCRUBBERS

THE WORLD'S SIMPLEST PEELERS WITH THE BEST PRODUCT CONTROL

Lyco Manufacturing, Inc. has over 50 years of experience making potato and other food processing machinery. 50 of the Top 100 food processors in North America rely on our expertise in peeling, heating, cooling, and screening. We have sold over 375 peelers, for raw and after steam peeling of potatoes and onions; and scrub clean white potatoes, sweet potatoes, and beets.



WAR HORSE



BULL JR.



RAGING BULL



Brushes

Our drive trains have fewest parts and lowest maintenance in the industry.



Abrasive

## BENEFITS OF LYCO'S PRECISION DRIVE TRAIN:

### LOW MAINTENANCE

- Fewer parts in every model
- No belts, chains or sprockets
- Auger raises with cover for access
- Easier to clean and change rolls

### PRECISE PROCESS CONTROL

- Full length auger
- Hydraulic or electric motor drive
- No under-peeling or over-peeling
- Higher yields come from precision

### SUGGESTED APPLICATIONS



SWEET POTATOES

WHITE POTATOES

RED BEETS

CARROTS

FRENCH FRIES



For more information visit: [www.LycoMfg.com](http://www.LycoMfg.com)



THE **EXPERTS** IN INNOVATIVE  
FOOD PROCESSING MACHINERY

## TRUST IN LYCO'S 50 YEARS OF EXPERIENCE

50 of the Top 100 North American food companies that feed the world trust and rely on Lyco Food Processing Machinery.

Our innovations in the Heating/Cooling and Liquid-Solid Separation machinery have made us a global leader and experts in the food processing industry.

Our extensive equipment offerings include:

- Blanchers/Cookers/Coolers
- Wastewater/Liquid-Solid Separation
- Peelers/Washers/Scrubbers
- Green Bean Equipment
- After Market Services

For more information visit: [www.LycoMfg.com](http://www.LycoMfg.com)



Lyco Manufacturing, Inc.  
115 Commercial Drive, P.O. Box 31  
Columbus, WI 53925

P: 920-623-4152

F: 920-623-3780

E: [sales@lycomfg.com](mailto:sales@lycomfg.com)

[www.LycoMfg.com](http://www.LycoMfg.com)

Nov225011





**LYCO**  
*Manufacturing, Inc.*

THE *EXPERTS* IN INNOVATIVE  
FOOD PROCESSING MACHINERY

**POTATO  
MACHINERY**



# LYCO HEATING AND COOLING TECHNOLOGY

Lyco Manufacturing, Inc. has over 50 years of experience making innovative food processing machines and screens.

## ROTARY DRUM BLANCHERS

Many different models of rotary drum blanchers have been developed over the years. Lyco has shipped 900 blanchers since 1985.

**Rotary Drums:** cylinders have augers covered with screens that carry 200 pounds of product between each pair of flights.

**Water Blancher applications:** potatoes, peas, corn, green beans, carrots, dry beans, rice, pasta, spinach, kale, and onions.

**Vapor-Flow® Steam Blancher applications:** shredded, slabbed, or diced potatoes, peas, corn, carrots, peppers, spinach, pickles, and onions.



Rotary Drum Water or Steam Cooker-Cooler



Clean-Flow® Cooker/Cooler

## CLEAN-FLOW'S® LOWER LABOR DESIGN

Clean-Flow® is an open auger design without fixed screens. A wedge wire basket underneath contains product between the auger flights. Hydro-Flow® Agitation keeps the products suspended and gently turning over, which eliminates inconsistent processing.

During cleaning the auger, basket and discharge wheel are rotated 360 degrees under CIP Sprays until the entire interior of the machine is 95% self-cleaned, which greatly reduces labor.

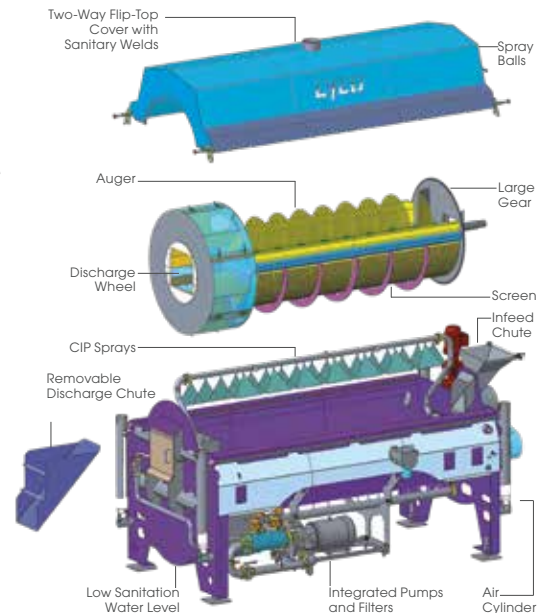

### CLEAN-FLOW® BENEFITS:

- Stores recipes
- Rapid cleaning
- Low maintenance
- Suspends product
- Higher quality and recovery
- Eliminates dense mass loading
- No under- or over-cooking
- Each particle is uniform
- No product damage
- Reduced waste

### SUGGESTED APPLICATIONS



PASTA

DRY BEANS

PROTEINS

VEGETABLES

RICE

POTATOES

CHIPS

For more information visit: [www.LycoMfg.com](http://www.LycoMfg.com)

# LYCO WASTEWATER SCREENS

## SINGLE AND DOUBLE DRUM SCREENS

In the 1980's, Lyco's first screens were made for the canning and freezing industry. Single Drum Screens were used for dewatering food items and simple waste-water applications. As applications became more complex we developed our Double Drum Screen. Lyco screens are now recognized as the world's best and most robust designs.

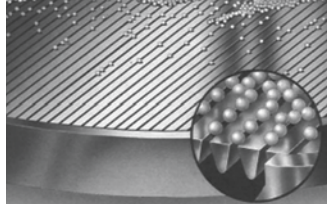

**PRECISION WEDGE WIRE**



**ONE TRAVELING SPRAY**



**NO FAIL RINGS**



**DOUBLE DRUM SCREEN ACTION**

We don't compete on price at Lyco because we make the best screens in the world. We design our equipment to be precise, sanitary, cleanable, and robust. We build longevity into our machines for year-round, continuous applications such as potatoes. Our precision made running rings don't fail because they are heavier more robust designs.

### PLANT DISCHARGE REDUCTION:

**TKN: 30%**

**TSS: 53%**

**COD: 34%**

**TDS:20%**

# LYCO'S NEW EXTERNAL-FLOW™ SCREEN IS THE BEST IN THE WORLD

Lyco's latest innovation, the External-Flow™ Screen, is the perfect solution for screening materials that won't easily pass through screens by gravity.

Material enters a headbox behind the cylinder and adheres to the top of the screen. It travels over the top to the other side, where a doctor blade scrapes the material. The water screens as it flows through the cylinder.



### BENEFITS:

- Lyco has over 2,300 screens used in the food industry
- Proven rugged, low-maintenance construction
- Doctor blade helps reduce blinding
- Lower BOD, TSS, and TKN with reduced hauling costs and higher recovery
- Uses less chemicals in post-water treatments

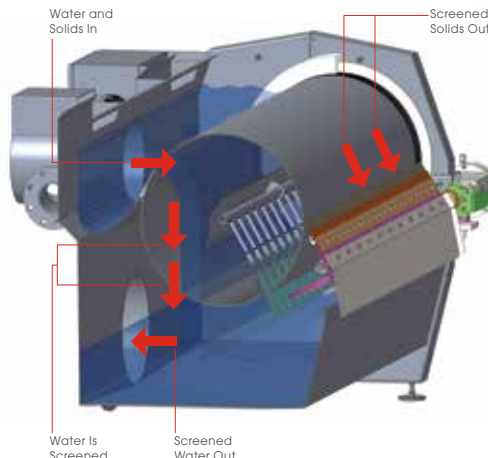

Lyco's External-Flow™ Screen have features no other designs have.



Micro Drum Screen

## MICRO DRUM SCREENS REMOVE 30% MORE WASTE

AND EVERYONE NEEDS TO REMOVE MORE SOLIDS!

Standard food wastewater screens can remove items larger than .020 inches in diameter. Lyco's Micro Drum Screens use three changeable types of screens to remove waste material as small as .008 inches to .005 inches in diameter - effectively removing 30% more solids.

### APPLICATIONS:

- Vegetable waste
- Potato waste
- Carrot peel waste
- Seafood waste
- Poultry waste
- Pet food waste

### BENEFITS:

- Reduce city loading
- Increase lagoon life
- Reduce DAF chemicals
- Automated CIP

### ON-SITE TEST IMPROVEMENT RESULTS:

BOD: 24.4%	TSS: 29.51%	TKN: 14.79%
------------	-------------	-------------

## REDUCE WATER COST BY USING IT AGAIN IN SECONDARY APPLICATIONS

You can drastically reduce ever-rising water costs by effectively screening and reusing your processing water.

Lyco's Sanitary Zero Maintenance Screen eliminates daily lubrication and reduces labor because of its very simple design.

A dual-canister filtering system senses plugged filters and will automatically change them on-the-fly, reducing post-treatment costs.

### LESS THAN ONE YEAR-RETURN ON INVESTMENT\*

24 inch diameter x 72 inch screen will save up to 350 gal/min  
 2 shifts x 260 days per year = 82 million gal/year  
 Savings of 82 million gallons of water will save  
**\$350,000-400,000 per year**

\* Typical, initial investment will cost \$150,000-200,000.

**SEND US YOUR COSTS FOR AN ROI ANALYSIS!**

**3.0**  
 BILLION  
 GALLONS

AMOUNT OF WATER  
**REUSED**  
 BY LYCO CUSTOMERS  
 IN 2022

### SUGGESTED APPLICATIONS



PROTEINS VEGETABLES POTATOES MEAT PROCESSING WASTEWATER



Zero Maintenance Screen



Dual Filter System

For more information visit: [www.LycoMfg.com](http://www.LycoMfg.com)